



The pursuit of the perfect in-counter scanner:  
open up our newest chapter.

 **Metrologic®**



Introducing Stratos™  
Metrologic's high performance  
6-sided bi-optic in-counter scanner/scale series.

Designed for the most demanding, high volume, supermarket  
and point-of-sale applications.



100 mm (4 in.) Below Counter Depth

Thinnest of all high performance, 5- and 6-sided bi-optic scanners

# MS2020

# 35 Years of Innovation, Value and Service

Satisfying customer expectations. We've been doing it since 1968.

From the warehouse to the distribution center to the checkout, Metrologic takes pride in serving retail, hospitality, healthcare, manufacturing, transportation, logistics and a host of other markets with superior point-of-sale and automatic data capture products. At Metrologic, we don't just respond to the changing needs of our customers and their markets. We anticipate them. By doing so we not only innovate, we foster strong relationships with our customers.

Stratos marks the beginning of a new era; the current destination in our pursuit of perfection. With Stratos we introduce a true flagship. A product that delivers significant advances and sets new standards in high-volume POS scanning. Based on years of experience and carefully considered anticipations, our engineers explored a number of innovative avenues and created the highest performing bar code scanner in an industry-leading package. Congratulations to us. Good news for you.

And if its more than high performance bi-optic scanning that you're after, you're in good hands. Stratos joins a strong family of POS hand-held, fixed and mini-slot scanners; portable terminals; miniature scanning engines; and over-the-belt industrial scanners and image acquisition systems. We provide features, value and service to customers in more than 100 countries through a growing network of sales, service and distribution offices in North and South America, Asia and Europe. We are determined to offer honest and fair dealings with every customer who does us the honor of pursuing business with Metrologic.



Corporate Headquarters, Blackwood, New Jersey, USA



Stratos**SCAN**™ Stratos**SWAP**™ Stratos

**SPEED**



## **RSS-14 Decoding**

Decodes RSS-14, RSS Limited and RSS Expanded emerging symbologies in addition to all standard 1D bar codes.



From its brilliant blue indicator to its smooth charcoal body and black accents, Stratos exudes quality and beauty. Its tasteful above-counter

design speaks of its high-performance upbringing. In fact, everything about Stratos is purposeful; designed to take high-volume POS scanning to new heights.

**Speed. Because you don't want your customers waiting in line.** Time is money. And nowhere is that more apparent than at the checkout. With Stratos**SCAN**™ 6-sided, 360° scanning, advanced Stratos**SPHERE**™ decoding software, 6000 scans per second, and a class-leading 68 scan lines, Stratos' performance is sure to get customers through fast. And thanks to Stratos**SCAN**, operators also benefit from minimized fatigue and stress associated with twisting and turning products.

**Uptime. Because you don't want your scanner waiting for a repair technician.** You only have a certain number of lanes per store. Each needs to be ready for action when it's convenient for your customers. That's why Stratos is constructed like a tank and tested to withstand the rigors of today's checkout environ-

ment. But we've faced reality, scanners sometimes malfunction, so Metrologic invented Stratos**SWAP**™ modular optics engine technology – small, pre-aligned, field-replaceable modules that pop into place in a matter of minutes. Simple. No need for full-unit spares taking up warehouse space. No need for degreed engineers on-call. What's more, Stratos' vertical and horizontal scanning zones operate totally independently from one another – a feature we call Stratos**SYNC**™. If one goes down, the other keeps scanning to keep your customers moving.

**Return on investment. Because we don't want you waiting to realize increased profit.** It starts with value pricing. Then we add features like Stratos**SCHOOL**™ operator training software and Stratos**STATS**™ code checking software to monitor characteristically hard-to-scan codes, a solid "bumper to bumper" warranty and, because every dollar counts, our light 15lb. (non-scale) unit even costs less to ship.

From the Counter Down  
(a scant 4 inches might we add)  
Stratos is Designed for Speed, Uptime and Return on Investment.

**So why are you waiting?** There's no better time to consider replacing your old flatbed scanners, upgrading your existing 4- and 5-sided dual-plane scanners or upgrading to a scanner/scale. Call us or click on the new products banner at [www.metrologic.com](http://www.metrologic.com).

**SCHOOL**™ Stratos**SCOPE**™ Stratos**STATS**™ Stratos**SPHERE**™ Stratos**SYNC**™

# SERVICEABILITY



**>>> StratosSWAP**  
Field replaceable optical scanning modules can be replaced in minutes.

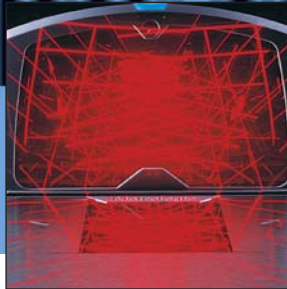

**>>> StratosSYNC**  
Independent vertical and horizontal scan zones



**>>> StratosSCOPE**  
Visual diagnostic indicator provides immediate, easy-to-read feedback on scanner condition.

# StratosSCAN™

6-sided, 360°  
scanning technology

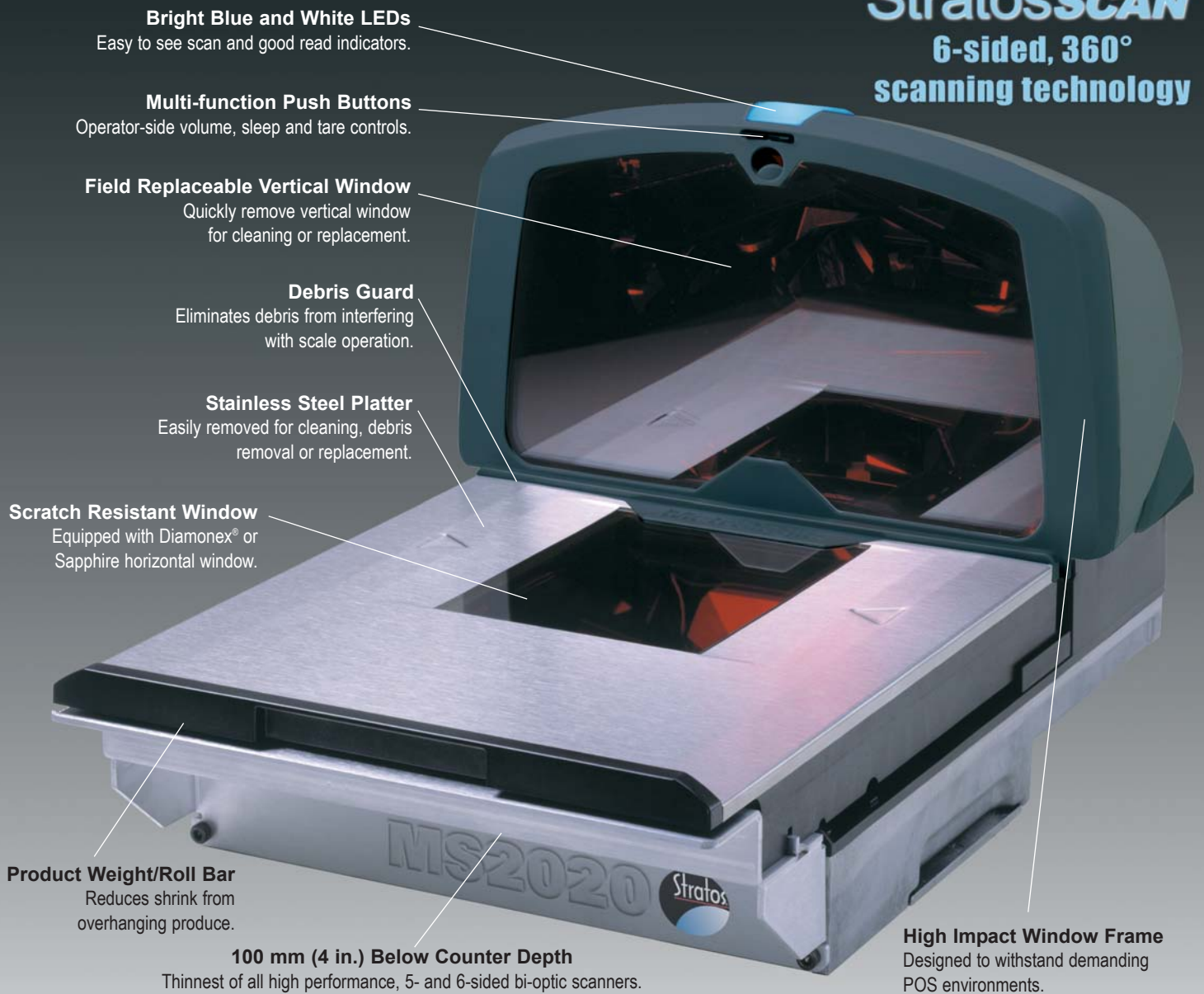

**Bright Blue and White LEDs**  
Easy to see scan and good read indicators.

**Multi-function Push Buttons**  
Operator-side volume, sleep and tare controls.

**Field Replaceable Vertical Window**  
Quickly remove vertical window for cleaning or replacement.

**Debris Guard**  
Eliminates debris from interfering with scale operation.

**Stainless Steel Platter**  
Easily removed for cleaning, debris removal or replacement.

**Scratch Resistant Window**  
Equipped with Diamonex® or Sapphire horizontal window.

**Product Weight/Roll Bar**  
Reduces shrink from overhanging produce.

**100 mm (4 in.) Below Counter Depth**  
Thinnest of all high performance, 5- and 6-sided bi-optic scanners.

**High Impact Window Frame**  
Designed to withstand demanding POS environments.

## Features Set Stratos Apart

- >> **StratosSCAN™**  
6-sided, 360° scanning minimizes product orientation.
- >> **StratosSPHERE™ Decoding Software**  
Reads poor quality and damaged bar codes.
- >> **BackPack™**  
Customer interaction peripheral system.
- >> **RSS-14 Decoding**  
Decodes RSS Limited and RSS Expanded symbologies.
- >> **Easy to Install**  
Fits existing counter openings.
- >> **Flash ROM**  
Upgrade latest software enhancements on-site.
- >> **Powered Aux Port**  
Connect hand-held scanner for large or bulky items.
- >> **Integrated Scale**  
Factory integrated or field upgradeable scale.
- >> **Loud Speaker**  
3 volume/7 tone settings can be heard in all environments.
- >> **Easy Programming**  
Windows® based utility or simple bar code setup.
- >> **Fully Automatic**  
“No touch” infrared wake up from power save modes.
- >> **EAS Deactivation**  
Electronic Article Surveillance (EAS) included.

# MS2020 Series **Stratos**<sup>TM</sup>

## OPERATIONAL

Light Source	Visible Laser Diode 650 nm $\pm$ 10 nm
Laser Power (horiz / vert)	1.25 mW / 2.25 mW
Depth of Scan Field - horizontal	0 mm - 152 mm (0" - 6") for 0.33 mm (13 mil) bar code
Depth of Scan Field - vertical	0 mm - 216 mm (0" - 8.5") for 0.33 mm (13 mil) bar code
Scan Speed	6000 scan lines per second
No. of scan lines (horz / vert)	68 (40 / 28)
Motor Speed - horz / vert	4800 / 6000 RPM
Sides Read	6
Scan Zone	360°
Minimum Bar Width	0.152 mm (6.0 mil)
Decode Capability	All standard 1-D bar codes, RSS-14, RSS-Expanded, RSS-14 Limited
System Interfaces	RS-232, Aux. RS-232, IBM468x/469x, USB (low speed and full speed), OCIA
Print Contrast	35% minimum reflectance difference
Number Characters Read	Up to 80 data characters
Roll, Pitch, Yaw	360°, 60°, 60°
Speaker Operation	7 tones or no beep; - 3 volume settings
Indicators (LED)	Blue = laser on, ready to scan; White = good read, decoding

## MECHANICAL

Length	MS2020 (full size scanner with scale)	508 mm (20.0")
	MS2021 (full size scanner only)	508 mm (20.0")
	MS2022 (compact size scanner only)	420 mm (16.5")
Width	286 mm (11.3")	
Depth (below counter)	101 mm (4.0")	
Height (above counter)	178 mm (7.0")	
Weight	MS2020 (full size scanner with scale)	9.1 kg (21 lbs)
	MS2021 (full size scanner only)	7.2 kg (16 lbs)
	MS2022 (compact size scanner only)	6.8 kg (15 lbs)

## SCALE CAPACITIES

Capacity	13.6 kg (30.0 lb)
Minimum increment	0.005 kg (0.01 lb)
Maximum static weight	68 kg (150 lb)
Adjustments required	Calibration only

## ELECTRICAL

Input Voltage	5V @ 1.5 Amps / 12V @ 1.5 Amps
Power	13.5 Watts (when scanning); 5 W (standby)
Operating Current	900 mA (5V) / 700mA (12V)
DC Transformers	Class II; 5 VDC @ 1.5 A; 12 VDC @ 1.5 A
Laser Class	CDRH & IEC: Class according to IEC 60825-1:1993+A1:1997+A2:2001
EMC	FCC, ICES-003 & EN55022 Class A

## ENVIRONMENTAL

Operating Temperature	0°C to 40°C (32°F to 104°F)
IP Rating	IP 55
Light Levels	4842 Lux (450 footcandles)
Storage Temperature	-40°C to 60°C (-40°F to 140°F)
Humidity	5% to 95% relative humidity, non-condensing
Contaminants	Sealed to resist airborne particulate contaminants
Ventilation	None required

## Dimensions

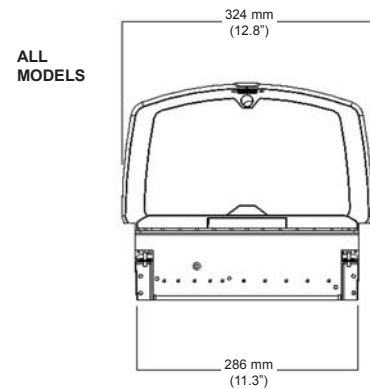

MS2022

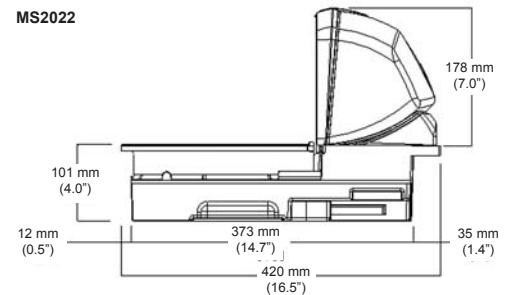

MS2021  
MS2020

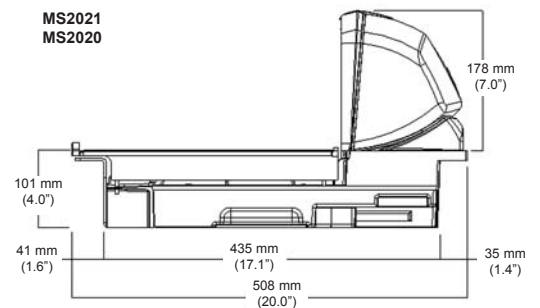

**RUOSS-KISTLER AG, Kantonsstrasse 55, 8863 Buttikon**

Tel.: (+41) 055 464 35 15 Mail: [handel@ruoss-kistler.ch](mailto:handel@ruoss-kistler.ch)  
Fax: (+41) 055 464 35 01 Internet: [www.ruoss-kistler.ch](http://www.ruoss-kistler.ch)